



# ***Product Catalogue***



# *R-APA Radial Unit Heater*



## Technical Specifications

# RADIAL UNIT HEATER

R-APA Series radial unit heaters are the ideal fans to meet the heating needs of high ceiling areas. Thanks to their compact construction, they can be mounted directly on the wall. R-APA radial units have high performance, trouble-free operation.

As a standard, with 90/70 °C hot water working regime, produced in the capacity of 5.000 –60.000 kcal/h. Upon request, can be produced according to working conditions with superheated water or steam.

Made of high quality corrosion resistant galvanized steel. Directly coupled backward curved bladed radial fan is used for air blowing. Heater coil is manufactured as copper pipe aluminum finned. It is manufactured as standard (380 V - 50 Hz) or other voltages and frequencies. Motors can be single-speed or double speed and have Class H, S1, IP55 insulation.

### Usage Areas

It can be used in closed areas, warehouses, hangars, workshops, gyms, garages, production facilities with a ceiling height exceeding 4m.

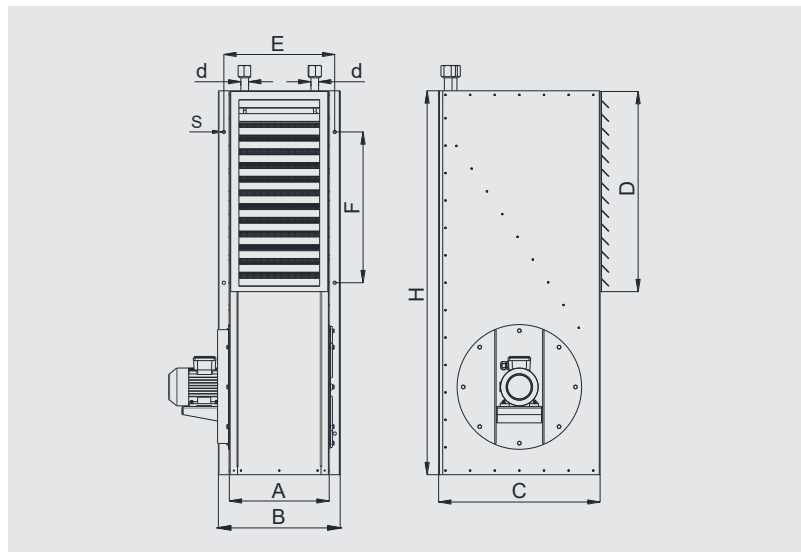

	A	B	C	D	E	F	H	S	d	VOLTAGE	FREQUENCY	MOTOR POWER	MOTOR SPEED	FLOW RATE	HEATER CAPACITY	SOUND PRESSURE LEVEL	WEIGHT	
MODEL	mm	mm	mm	mm	mm	mm	mm	mm	mm	V	Hz	kW	rpm	m <sup>3</sup> /h	kcal/h	kW	dBa	kg
R-APA-5	260	340	520	510	300	320	940	12	¾"	380	50	0,25	1380	1300	5000	5,8	72	66
R-APA-6	260	340	520	510	300	320	940	12	¾"	380	50	0,25	1380	1300	6000	7,0	72	66
R-APA-8	260	340	520	510	300	320	940	12	¾"	380	50	0,25	1380	1300	8000	9,3	72	78
R-APA-10	260	340	520	510	300	320	940	12	¾"	380	50	0,25	1380	1300	10000	11,6	72	78
R-APA-12	350	430	520	590	390	420	1135	12	1"	380	50	0,25	1380	2200	12000	14,0	74	96
R-APA-18	350	430	520	590	390	420	1135	12	1"	380	50	0,25	1380	2200	16000	18,6	74	116
R-APA-20	350	430	520	590	390	420	1135	12	1"	380	50	0,25	1380	2200	20000	23,3	74	133
R-APA-24	365	445	590	730	405	550	1400	12	1"	380	50	0,37	1390	3300	24000	27,9	75	149
R-APA-28	365	445	590	730	405	550	1400	12	1"	380	50	0,37	1390	3300	28000	32,6	75	149
R-APA-32	365	445	590	730	405	550	1400	12	1"	380	50	0,37	1390	3300	32000	37,2	75	172
R-APA-40	455	530	640	1010	490	690	1680	12	1¼"	380	50	0,75	1370	5300	40000	46,5	76	223
R-APA-50	455	530	640	1010	490	690	1680	12	1¼"	380	50	0,75	1370	5300	50000	58,1	76	261
R-APA-60	455	530	640	1010	490	690	1680	12	1¼"	380	50	0,75	1370	5300	60000	69,8	76	265

*Minarelicavus OSB District 202. Street No: 19 Nilüfer/Bursa Turkey  
T: 90(224)482 50 95 E: info@fanturk.com.tr*

***fanturk.com.tr***



# ***Product Catalogue***



# A-APA Axial Unit Heater



## Technical Specifications

# AXIAL UNIT HEATER

A-APA series axial unit heaters are the ideal fans to meet the heating needs of high ceiling areas. A wall-mounted construction is used for mounting. A-APA axial units have high performance, trouble-free operation.

As a standard, with 90/70 °C hot water working regime, produced in the capacity of 4.100 – 24.200 kcal/h. Upon request, can be produced according to working conditions with superheated water or steam.

Made of high quality corrosion resistant galvanized steel. Directly coupled backward curved bladed radial fan is used for air blowing. Heater coil is manufactured as copper pipe aluminum finned. It is manufactured as standard (380 V - 50 Hz) or other voltages and frequencies. Motors can be single-speed or double speed and have Class F, S1, IP55 insulation.

### Usage Areas

Can be used in closed areas, warehouses, hangars, workshops, gyms, garages, production facilities with a ceiling height exceeding 4m.

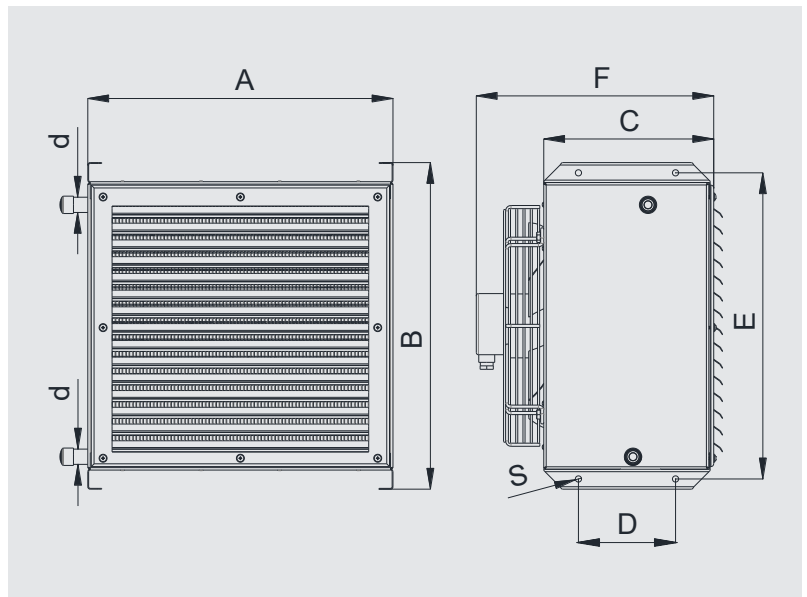

MODEL	A	B	C	D	E	F	S	d	VOLTAGE	FREQUENCY	MOTOR POWER	FLOW RATE	HEATER CAPACITY		SOUND PRESSURE LEVEL	WEIGHT
	mm	mm	mm	mm	mm	mm	mm	inç	V	Hz	W	m <sup>3</sup> /h	kcal/h	kW	dBA	kg
A-APA 6	460	475	230	140	443	325	4,5	¾"	230	50	50	800	4100	4,8	55	17
A-APA 10	460	475	230	140	443	325	4,5	¾"	230	50	90	1200	6000	7,0	60	19
A-APA 12	460	475	230	140	443	325	4,5	¾"	230	50	90	1400	8600	10,0	52	20
A-APA 16	460	475	230	140	443	325	4,5	¾"	230	50	138	1600	11000	12,8	53	22
A-APA 20	460	475	230	140	443	325	4,5	¾"	230	50	138	1725	12700	14,8	60	22
A-APA 24	555	565	300	160	535	425	4,5	1"	230	50	138	1800	16400	19,1	62	27
A-APA 32	555	565	300	160	535	425	4,5	1"	230	50	138	1900	20600	24,0	64	28
A-APA 40	555	565	300	160	535	425	4,5	1"	230	50	180	2450	24200	28,1	65	29

*Minarelicavus OSB District 202. Street No: 19 Nilüfer/Bursa Turkey  
T: 90(224)482 50 95 E: info@fanturk.com.tr*

*fanturk.com.tr*