

• • • • •
• • • • •
• • •
• •

AIRFLOWCONTROL

Design Manual

System Components
for Air Distribution



TROX[®] TECHNİK

The art of handling air

Table of contents

Experience and innovation	3
Air distribution	4
Volume flow measurement	6
Volume flow control	8
Room temperature control	10
Pressure control	11
Fan speed control	12
CONSTANTFLOW	13
VARYCONTROL	14
Volume flow measurement equipment	17
EXCONTROL	18
Special solutions	19
Balancing and shut-off	20
Accessories	21
Room temperature controller	22
Control concepts	23
Control components	24
System integration	27
Design criteria	28
Documentation	29
Unit selection	30
Project execution	32
Commissioning	33
References	35



Manufacturing and adjusting volume flow terminal units

Ventilation equipment from TROX – Important components for a comfortable indoor climate

Ventilation and air conditioning systems are called upon to adjust indoor air quality and the conditions for heating comfort and humidity in a room so as to comply with established requirements (EN 13779).

One of the primary issues in this process is room climate. To maintain the necessary air quality and enable economic operation of the system, all air flows of a system must be monitored and controlled. The air-distribution equipment is thus given an important task.

TROX are one of the world's leading manufacturers of this equipment. Our international success is based on 35 years of development and production experience of air terminal units and related components.

Today, the product range provides technical solutions for all current applications. Office buildings, laboratories, schools, hotels and even passenger Liners are equipped with TROX system components for air distribution.

The TROX production plants around the globe are equipped with air test rigs, so that every unit leaves the factory perfectly set up to customer requirements.

At TROX, we also pride ourselves on service. Installation and wiring must be checked during commissioning. The information required for this is contained in our documentation. In addition, our service team can help you quickly and easily. For solutions with LONWorks® technology, you can trust us to handle the system integration.

The distribution of air by an air conditioning system involves a variety of tasks, which have led to the development of the following product groups while keeping the overall control concept in mind:

Volume flow control

VARYCONTROL type

Air terminal units with auxiliary power for system pressure-independent control of a variable air flow.

VARYCONTROL Easy type

Air terminal units based on the Easy philosophy: selection based on the nominal size, volume flow adjustment without additional special tools and functional check via indicators.

Mechanical system-powered controller

Volume flow control for constant air flows. These units do not require auxiliary power.

Volume flow measurement

Measurement of the air flow in duct sections, for the control of slave controllers and/or for display or monitoring.

Balancing and shut off

Air-tight shut-off and balancing of duct sections.

Explosion protection and special solutions

Volume flow control and shut-off in explosion-protected building areas. Special units for laboratory buildings, hotels and ships.

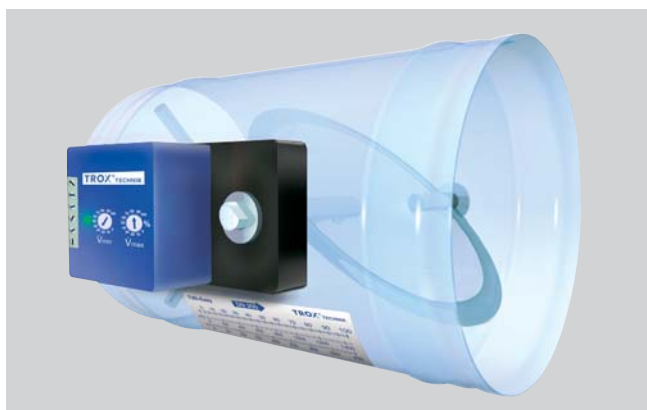

Air distribution

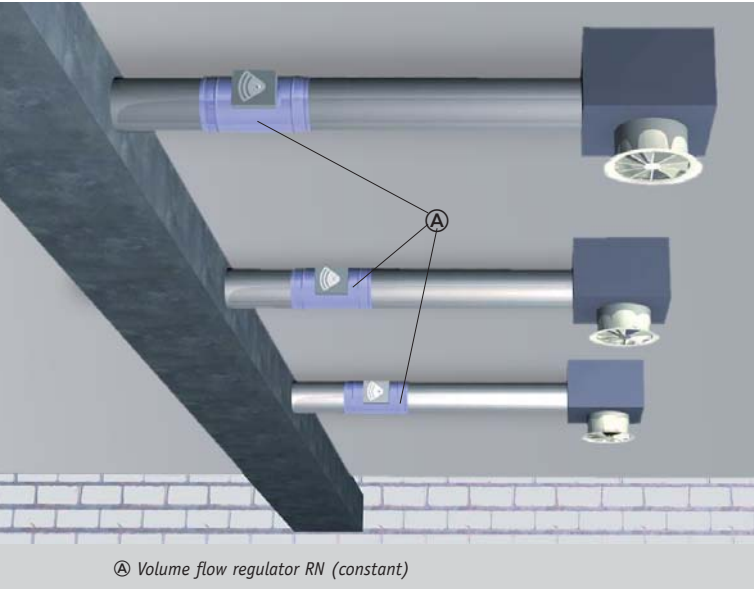

Air distribution

An essential feature for laying out air conditioning systems is air flow, which can be designed to be constant or variable. Accordingly, a differentiation is made between constant volume flow systems (CAV) and variable volume flow systems (VAV). These features can also apply to sections of a system since a combination of both types is technically feasible.

The system selected depends on the overall concept of the building services. A constant system is only possible where other systems ensure zone-based temperature control, e.g. heating surfaces, or where temperature control is not required.

As the central element of air distribution, the fan (or speed control) deserves close attention. Economic operation is only possible with fan speed control according to the specified requirements.



Hyundai Headquarters, Offenbach am Main, Germany

Constant volume systems

Constant volume systems provide every location with a constant airflow. However, a variety of systems with technical and economic differences are available.

Constant fan speed and balancing dampers

Commissioning of this system is very complex and time consuming. The air flow has to be measured in every branch. The dampers are adjusted based on the deviations. Measurement and adjustment are usually repeated until every section has the required flow rate. During the operation as filter contamination increases the air flow is reduced.

Constant fan speed and volume flow controllers

Measurement in all duct branches is not necessary. The fan speed must be set high enough that sufficient pressure is available for all controllers and the planned final pressure loss of the filters.

Variable fan speed and balancing dampers

Adjustment of the dampers is necessary. The fan speed control maintains the pressure level in the duct system, which keeps all air flows constant. In the case of clean filters with less pressure loss, the fan speed is correspondingly lower.

Variable fan speed and volume flow controllers

This system offers the most advantages, as no adjustment is necessary and operation is economic. If the demand changes, the setpoint value need only be adjusted at the controller.

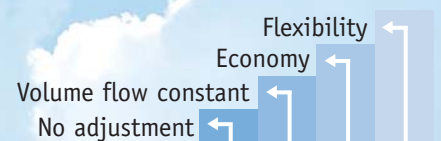

Constant fan speed				
Balancing dampers	-	-	-	-
Volume flow controllers	+	+	-	+
Variable fan speed				
Balancing dampers	-	+	+	-
Volume flow controllers	+	+	+	+

Air distribution

Systems with variable volume flow

Indoor air quality is especially important in air-conditioned buildings, where economic operation of air conditioning systems is to be taken into account. This can be achieved with variable volume flow systems. Every room or zone receives exactly the air flow rate required to maintain the necessary criteria. The control of air flows is with control components requiring auxiliary electrical or pneumatic power. In most cases, the room temperature control results in the ventilation requirement. The air quality can be considered likewise.

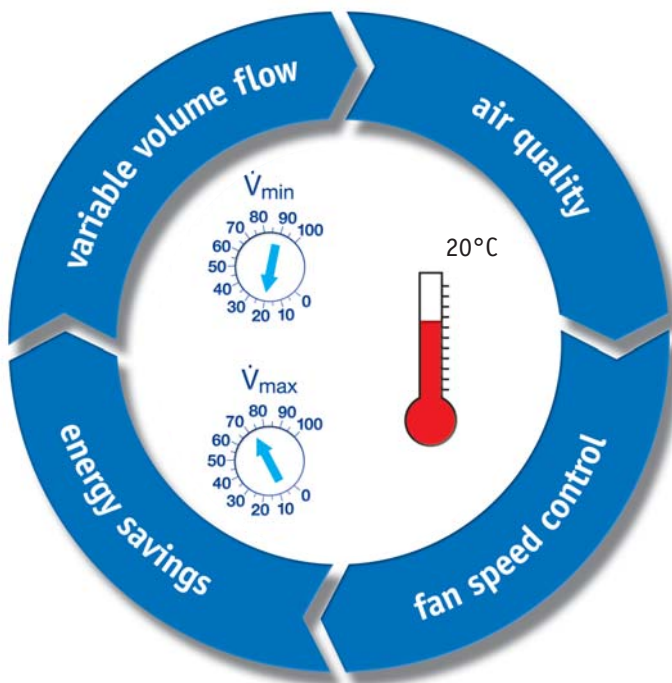

- individual control of each zone
- full shut-off and other override controls possible
- varying air flow between \dot{V}_{\min} and \dot{V}_{\max} or switching between operating points
- control circuits may not negatively affect one another
- setpoint value can be changed at any time
- Decentralised operation of controllers can be integrated into the building management system

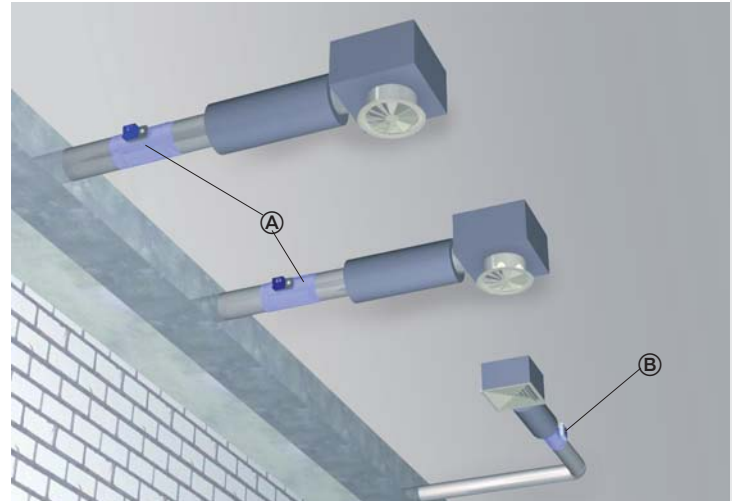

Ⓐ Volume flow controller TVR (variable)
Ⓑ Volume flow regulator RN (constant)

The energy-savings potential can be fully utilised with demand-based fan speed control. The static duct pressure at a reference point is used as a control variable. Systems that detect and optimise the damper blade position of all the controllers are even more efficient.

System combinations

Variable and constant sections can be mixed in an air-distribution system. Air terminal units for variable air flow and constant flow can be located next to one another in one section. Segments without volume flow controllers must be fitted with a air terminal unit with control components for duct pressure control.

Deutsche Telekom, Frankfurt, Germany



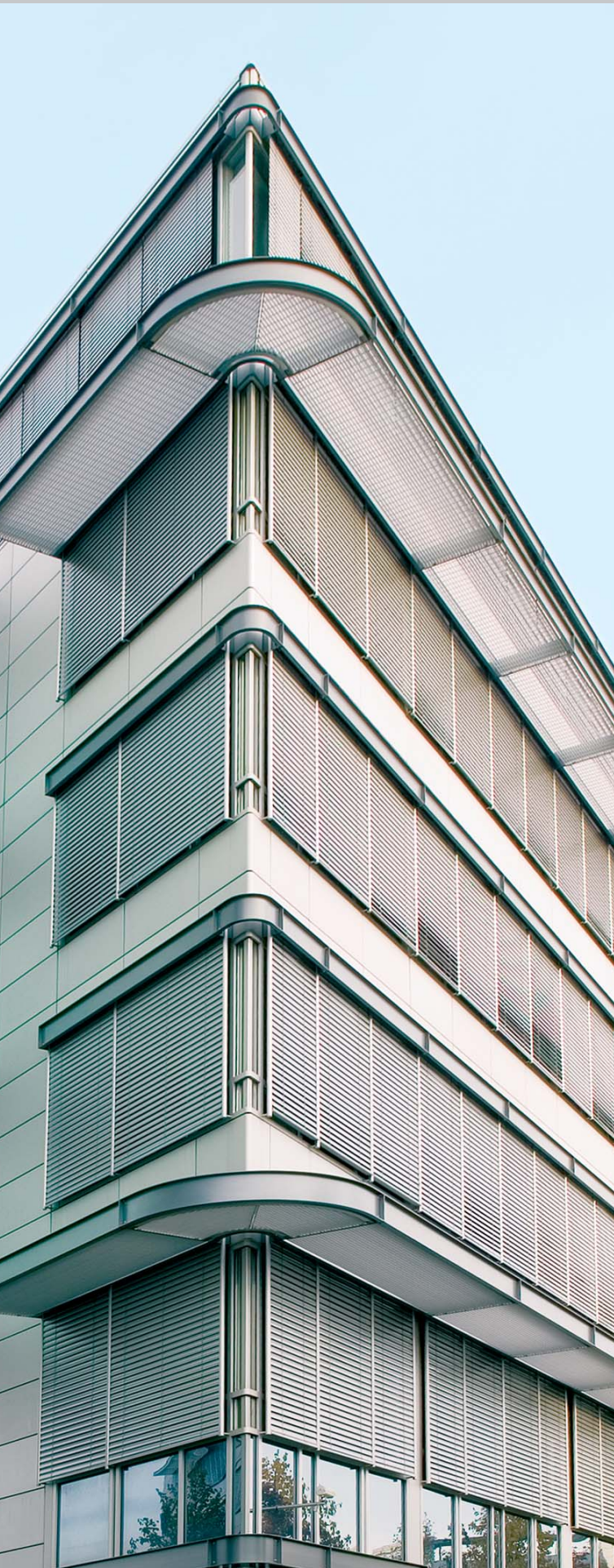

Volume flow measurement

Measurement accuracy is of crucial importance for every form of flow rate control. The measurement equipment of a air flow terminal unit deserves special attention for this reason. The air flow generates a measurable pressure differential at a location, this is called dynamic or velocity pressure which can be directly measured using a Prandtl pitot tube. This dynamic pressure is proportional to the square of the air velocity and provides the volume flow when the cross sectional area at the measuring location is taken into account. A straight length of duct is required to provide a uniform flow field for this type of measurement. This is the exception with systems in practice. The air terminal unit is often installed downstream of a bend. As can be seen in the figure the velocity profile distorts near the bend. Thus, a single point measurement directly after the bend is inaccurate and does not provide a usable result. Accurate results can only be achieved with a measurement location with approximately eight hydraulic diameters of straight ductwork downstream of the disturbance. However using a measurement grid with multiple measurement points distributed across the duct cross section provides much more reliable results close to the disturbance.

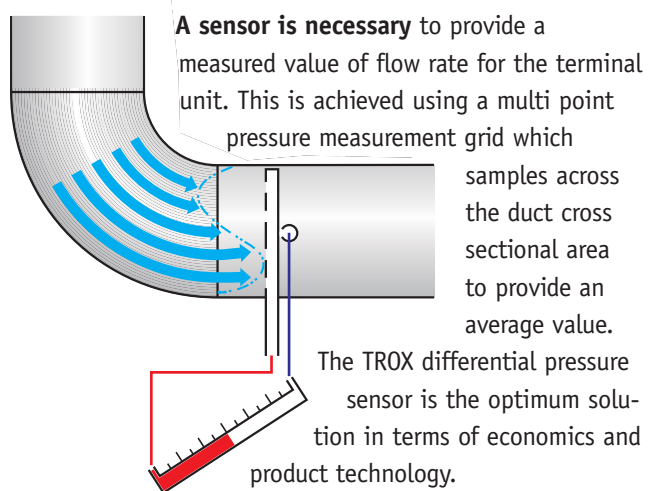

The sensor comprises of at least two measurement tubes with holes for the upstream and downstream sides. This provides good averaging in the respective measurement tubes. This sensor delivers exact results for most ventilation applications with normal upstream flow conditions.

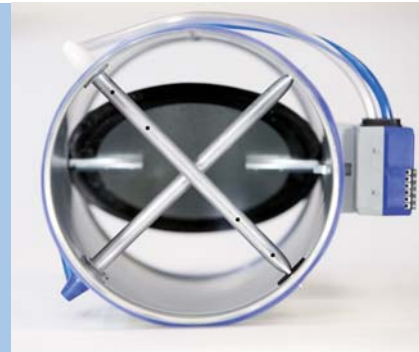

Scope of application: office building
VARYCONTROL TVZ and TVA with control components for integration
in building management system

Volume flow measurement

Measurement principles of the differential pressure transducer

An electrical or pneumatic signal is generated from the differential pressure for volume flow control. The electronic components can be based on one of two different methods referred to as dynamic and static measurement.

Dynamic differential pressure measurement

With dynamic measurement, a sample of the air stream (bypass) flows through the differential pressure transducer. The transducer is built like a miniaturised velocity-measurement duct. The transducer contains a heated element which loses an increasing amount of heat as the air velocity increases this can be used to provide an electrical signal related to air flow rate. Since the sample air flow is proportional to the total air flow, the measurement signal can be calibrated to the total air flow, and provides a voltage signal that has a linear relationship to the air flow.

This measurement principle is an economic solution for systems in offices and similar buildings. Due to possible contamination of the sensor, this measurement principle should not be used to measure air flows contaminated with dust and/or chemicals.

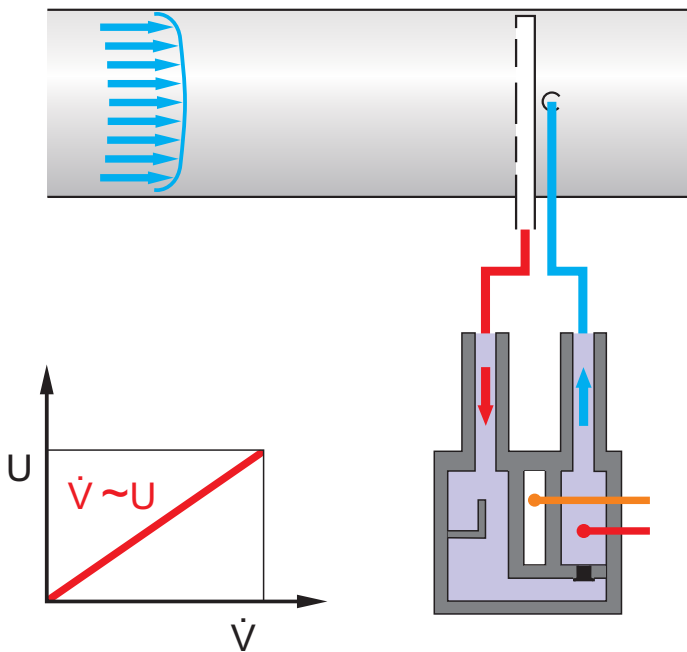

A comparison of measurement procedures		
Comparison	Dynamic	Static
Air flow range	10 to 100 %	approx. 17 to 100 %
Cost	100 %	250 %
Critical	pollution contamination	gravity dependance drift
Maintenance	none	recommended yearly

Static differential pressure measurement

Diaphragm pressure transducers operate based on the static pressure measurement principle. The sensor comprises of a cylinder and a diaphragm between two chambers, one each for positive and negative pressure. The diaphragm is in the centre when the pressure in both chambers is the same. A pressure differential causes the diaphragm to move toward the side with the lower pressure. This change in distance is a measurement of the differential pressure. This is why the voltage signal behaves proportionally to the differential pressure. The volume flow controller must be adjusted to match it and square root this signal.

With this measurement principle, no air flows through the sensor. This means that it is not susceptible to dust. It must be noted here, however, that chemical substances can reach the diaphragm and measurement chambers via diffusion and cause a reaction. However the risk is considerably less than with the dynamic measurement method.

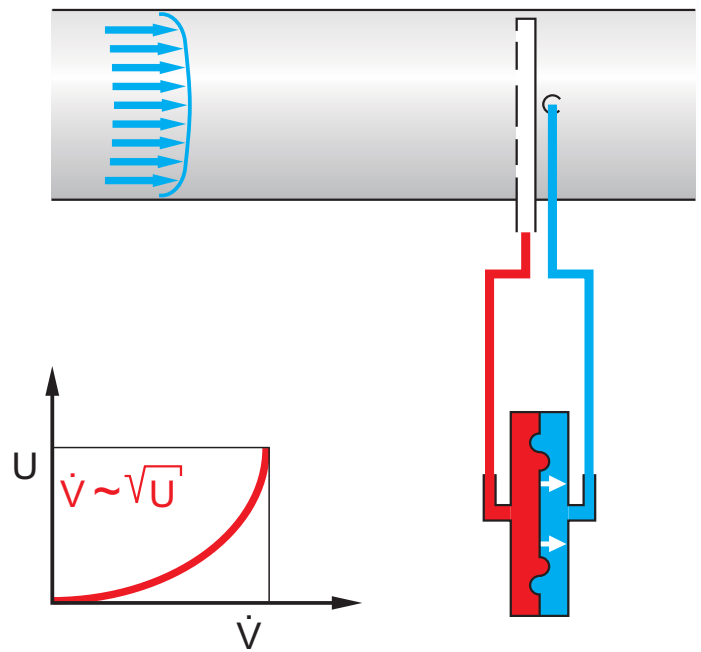



Nürnberger Versicherungen, Nuremberg, Germany

Volume flow control

Variable volume flow control with auxiliary power

The volume flow is controlled in a closed control loop, i.e. measurement – comparison – control. The controller receives the current actual value based on the differential pressure from the transducer. In most applications, the setpoint value comes from a room temperature controller. The controller compares the actual value with the setpoint value and alters the command signal of the damper actuator in the event of a difference between the two values.

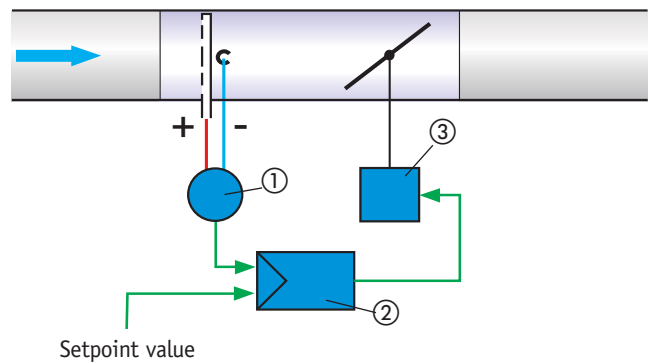

① Differential pressure transducer ② Volume flow controller ③ Actuator

Changes in duct pressure

If the duct pressure changes, e.g. due to the change in air flow of other units, this is detected and corrected by the controller. This prevents the room temperature being affected.

Variable volume flow

Once the input signal is changed, the air flow is adjusted to a new setpoint value. The variable volume flow is limited to a minimum and maximum value. Control can be changed with the override controls, e.g. full shut-off.

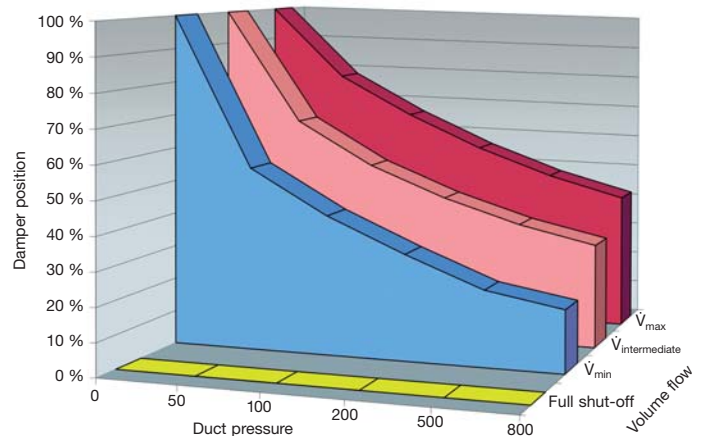

Volume flow control

Constant volume flow control without auxiliary power

Mechanical system-powered regulators are an economic solution for the control of constant air flows. Since they work without an external power supply, no wiring or commissioning is necessary.

The regulator contains a control damper supported by bearings. The aerodynamic forces of the air flow cause the damper to close. These forces are amplified by bellows. A mechanical unit consisting of a leaf spring and cam plate acts against the closure force keeping the flow rate constant as the duct pressure varies. The bellows also has the function of acting as an oscillation damper.

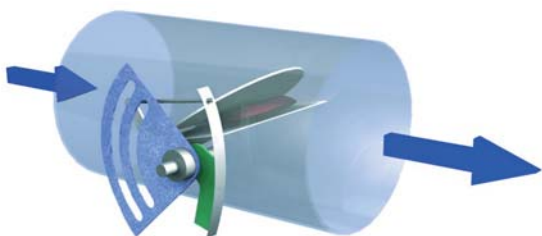

Commissioning of these units is especially easy. The desired volume flow can be read and, if necessary, set, at an external scale. TROX provides mechanical system-powered volume flow regulators types RN (circular) and EN (rectangular). The air-regenerated noise is reduced by fitting secondary silencers in case of more critical acoustic requirements.

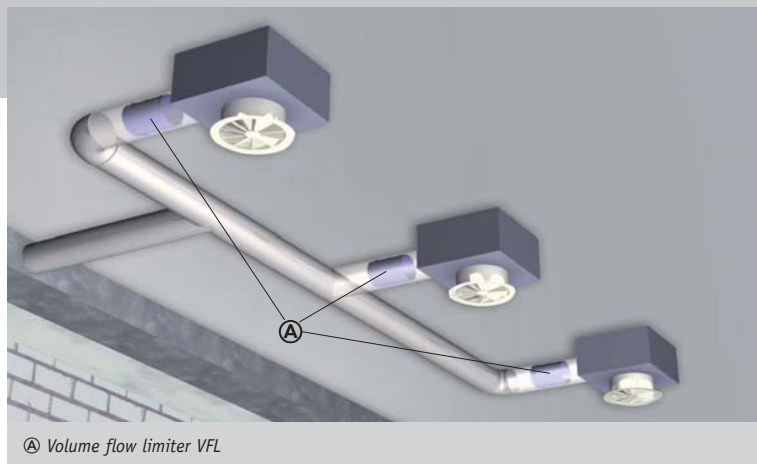

Constant volume flow control with setpoint value switching

Systems operated with constant air flow offer energy-savings potential if the air flow is reduced at unoccupied times (night setback switching). The volume flow regulators have two setpoint values that are used when switching. The volume flow regulators are fitted for this purpose with a two position actuator.

Volume flow limitation

Even air distribution among the multiple air diffusers only occurs with the appropriate duct layout or after adjustment of the balancing dampers. Volume flow limiters which slide into the duct at each diffuser make sense, since both commissioning is easier and quicker and exceeding of the design criteria is prevented. For acoustic reasons, the pressure differentials to be overcome should not be too high (low-pressure systems).



Huk-Coburg Versicherungen, Coburg, Germany

Room temperature control

Room temperature control

In VAV systems, the room temperature control takes the form of a cascade control. The primary controlled variable is the room temperature. The output signal of the room temperature controller is not fed directly to the supply air control damper, but alters the setpoint value of the supply air volume flow rate control circuit. The volume flow control also provides minimum and maximum limits for the air flow which has benefits in keeping the room temperature constant and for the functioning of the overall room air conditioning system:

- Fluctuations in the duct pressure do not affect the room temperature
- Minimum air flow ensures the best possible air quality, even with minimal cooling demand
- Maximum air flow keeps pressure losses and noise within the design criteria and prevent draughts
- Integration of the extract air into VAV mode is also possible

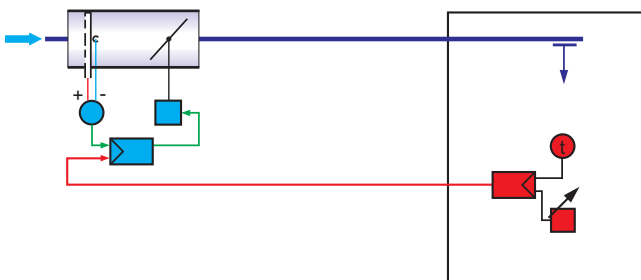

Override controls

The room temperature control can be deactivated via override controls. A window switch stops ventilation of a room when the window is open by closing the damper control. A higher level of ventilation (\dot{V}_{max}) or opening the control damper for smoke removal is possible.

Supply and extract air control

In individual rooms and closed-off office areas, where the balance between supply and extract air volume flow has to be maintained. Otherwise, annoying whistling noises can occur at door gaps, and the doors can be difficult to open. For this reason, the extract air should also have variable control in a VAV system.

Tracking control (master/slave)

The actual value of the supply air is fed as an input signal to the extract air controller (slave controller). In this way, the extract air automatically follows the supply air, even in the case where this has not reached its set point value. Under certain circumstances, it can make sense to swap the tracking over and give the extract air the master function.

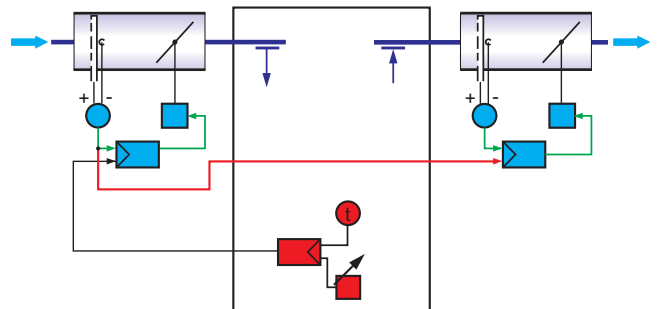

Parallel control

If the input signal of room temperature control is fed to both the supply air and extract air controller this provides parallel control. Both controllers have the same setpoint value. If the inlet pressure in a duct section is too low, unbalanced air distribution may occur. The sequence control is superior to parallel control due to the link to the actual value, at least in one direction.

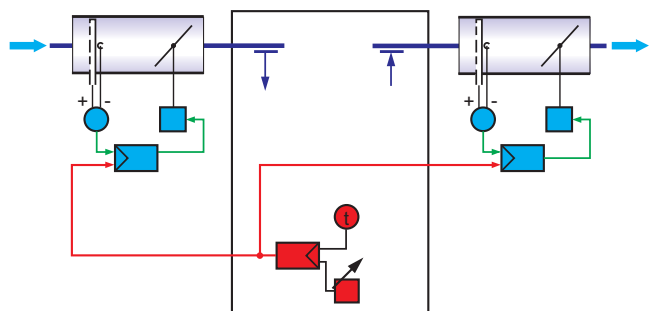

Schloß Moyland,
Kleve, Germany

Pressure control

Scope of application: laboratory building
Plastic volume flow terminal units TVLK
for the control of fume cupboards and
control of room pressure



Pressure control

Duct pressure control

Duct pressure control is also part of air distribution in room air conditioning systems. For buildings with long corridors and many similar rooms, the control expenditure is reduced when the static pressure in a duct section is controlled. Instead of having volume flow controllers for each room, an actuator controlled shut-off damper is used. The duct pressure control is taken over by the air terminal unit, which is equipped with control components which are specifically for this purpose.

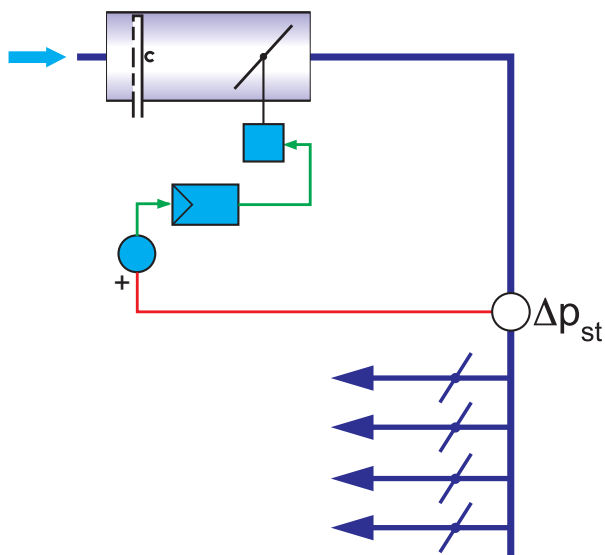

Room pressure control

The supply and extract air tracking control described above approaches its limits in very low leakage rooms, such as those often seen in hospitals, clean room projects and laboratories. For room pressure control, the static pressure differential of a reference room is measured with a diaphragm pressure transducer and controlled with the damper of the unit.

Room pressure and duct pressure control can also be expanded with volume flow measurement which can be used for display or tracking control.

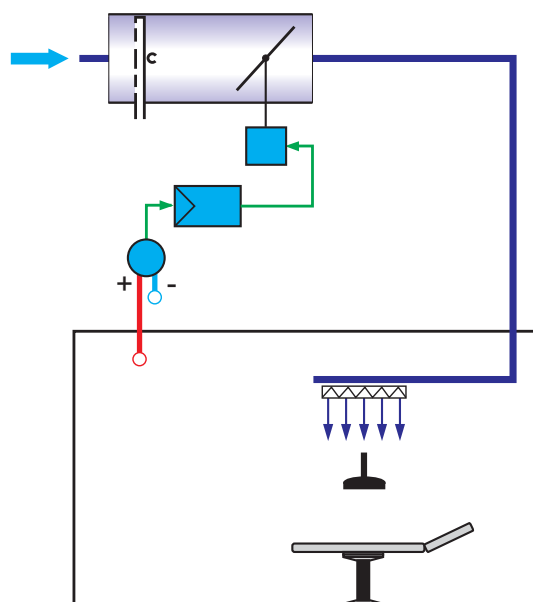

Fan speed control

Fan speed control

Minimum pressure differential

Sufficient system pressure is a requirement for trouble-free functioning under all operating conditions. This minimum pressure differential is documented in our technical literature. Allowance has to be made for pressure rise across the fan, this must include components in the duct work system and the duct work itself both upstream and downstream of the air terminal unit. The calculation of these pressure losses are required to size the fan and the pressure regulated fan speed control.

System pressure control

Pressure-regulated fan speed control is the modern standard. The selection of the measurement location for duct pressure control is important in this context. The pressure transducer is often positioned at the end of the longest duct run (an unsuitable point). With VAV systems, however, there is no unsuitable point since the air flow is demand-based.

If the controller found at the end of a duct run is in minimal mode, under certain circumstances the pressure in other duct runs may be insufficient.

Sufficient system pressure under every operating condition is only ensured when the pressure sensor is found near the fan before the first branch. Reduction of the setpoint value is possible however when diversity is taken into account some rooms may not achieve maximum flow.

Damper blade position control

The aforementioned fan speed control maintains a pressure setpoint value, but does not take into account that when the air flow decreases, required the pressure level also decreases. The detection and analysis of the damper blade positions for all air terminal units leads to further optimisation of the fan speed. This system responds dynamically to the largest individual demand, regardless of its location in the system. Special units and/or special software are required for this type of fan speed control. This is also only possible with actuators with analogue or digital position feedback.

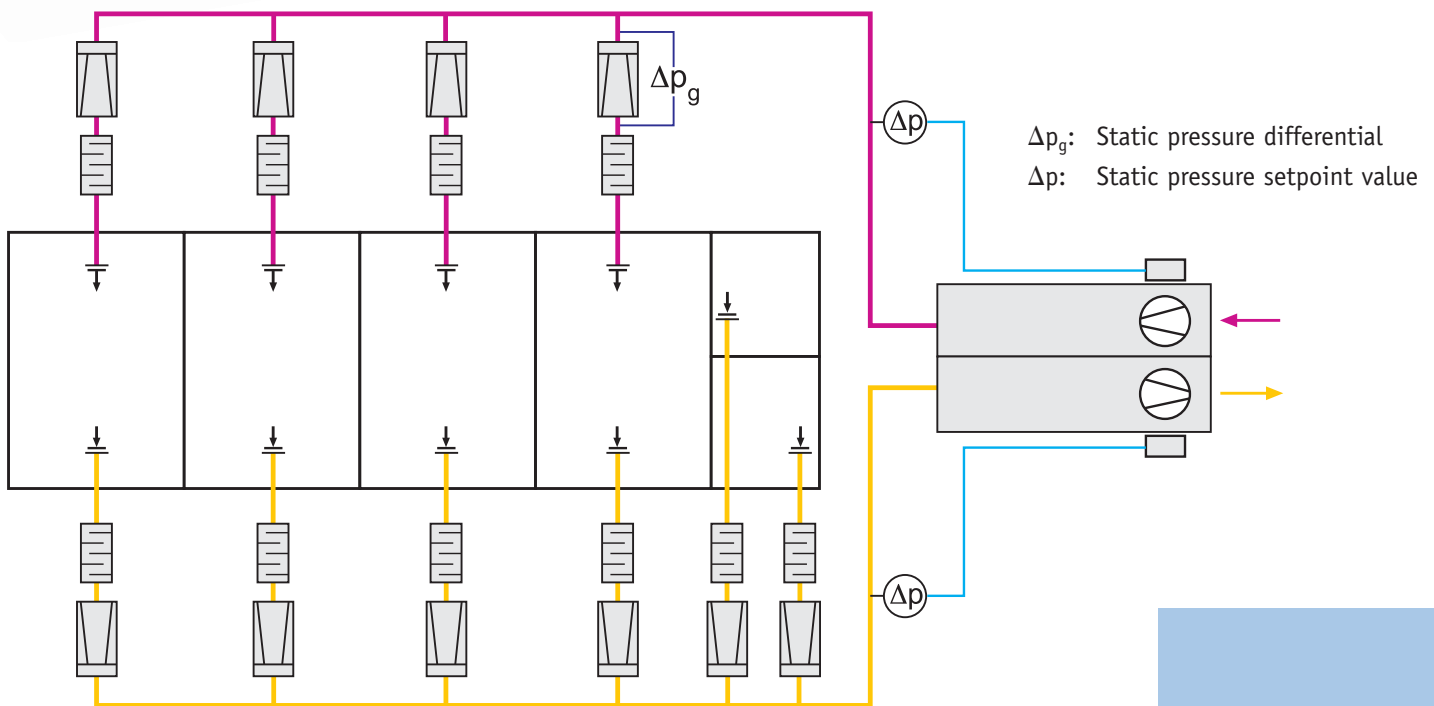

CONSTANTFLOW

Mechanical system-powered

Regulators for supply or extract air of constant volume flow systems

Constant volume flow regulators facilitate commissioning in constant volume systems (CVS). The desired air flow is set at an external scale (RN/EN). There is no other complex or time-consuming calibration. If duct sections with constant air flow are required in VAV systems, they must always be controlled, as other sections of the system are variable and can cause changes in pressure in the constant sections. Mechanical system-powered controllers are an interesting solution from a business perspective, as commissioning costs are considerably reduced.



RN – circular controller



EN – rectangular controller



VFL – volume flow limiter



- **Regulators for constant volume flow systems**
Duct installation without change to cross section
- **Mechanical system-powered**
No external power required
No wiring necessary
- **Option with actuator**
Switching to several setpoint values
Exception: VFL
- **Factory volume flow calibration and functional testing of each regulator**
All controllers are preset to reference volume flow ex works
Units essentially ready for commissioning after installation
No on-site calibration required
- **Adjustment of the volume flows**
Adjustment of the required volume flow directly at the regulator, based on the volume flow scale, no tools required
The plug-in volume flow limiter is set on-site before installation
- **Unit variants with acoustic cladding**
If the case-radiated noise is not adequately reduced by the respective false ceiling, the solution is a unit with additional acoustic cladding
Not possible with VFL
- **Accessories**
Secondary silencer for rooms with more stringent requirements on comfort
Reheat unit for RN and EN
Lip seal for RN

VARYCONTROL

VAV units

Air terminal units for more stringent acoustic requirements

VAV units of the VARYCONTROL type are box-style air terminal units for supply and extract air systems. They can be used for almost any control, regulation and shut-off tasks in room air conditioning systems, but are most ideal for systems with more stringent acoustic requirements.

Allianz-Versicherung,
Frankfurt am Main, Germany



TVZ – VAV unit for supply air



TVA – VAV unit for extract air



TVM – VAV unit for dual-duct systems



- **Terminal units for variable volume flow systems**
Reduction of the flow velocity (pressure reduction)
outlet with rectangular cross section
Integral silencer
- **Hygiene criteria**
Hygienically tested pursuant to VDI 6022
- **Air-tightness at full shut-off**
Leakage air flow pursuant to DIN EN 1751
- **Electronic or pneumatic control components**
TROX controller or the controllers of well-known controller manufacturers allow project-specific solutions
- **Factory volume flow calibration and functional testing of each unit**
Units are essentially ready for commissioning after installation
No on-site calibration required
- **Adjustment of the volume flows possible**
Adjustment to local conditions are made directly at the controller, for example with an adjuster unit
- **Measurement and display of the current volume flow**
The current actual value of the air flow provided as a voltage signal
Bus-capable controllers transfer the actual value as a variable
- **Unit variants with acoustic cladding**
If the case-radiated noise is not adequately reduced by the respective false ceiling, the solution is a unit with additional acoustic cladding
- **Accessories**
Secondary silencer TS, for rooms with the most stringent requirements for comfort
Reheat unit for TVZ
Lip seal

VAV controller

VAV controller for supply or extract air for a variety of applications

VAV controllers of the VARYCONTROL type are the functional equivalent of the box units when it comes to control. They are designed without an integral silencer, however, and cannot be used for applications with more stringent acoustic requirements without additional attenuation.

The same unit type is used for supply and extract air applications.

Hamburg Airport,
Hamburg, Germany



TVR – circular controller



TVJ/TVT – rectangular controller



TVRK – plastic circular controller



- **Controllers for variable volume flow systems**
Duct installation without change to cross section
- **Air-tightness at shut-off**
Leakage air flow pursuant to DIN EN 1751
Exception: TVJ
- **Electronic or pneumatic control components**
TROX controller or the controllers of well-known controller manufacturers allow project-specific solutions
- **Factory volume flow calibration and functional testing of each unit**
Units are essentially ready for commissioning after installation
No on-site calibration required
- **Adjustment of the volume flows possible**
Adjustment to local conditions are made directly at the controller, for example with an adjuster unit
- **Measurement and display of the current volume flow**
The current actual value of the air flow provided as a voltage signal
Bus-capable controllers transfer the actual value as a variable
- **Unit variants with acoustic cladding**
If the case-radiated noise is not adequately reduced by the respective false ceiling, the solution is a unit with additional acoustic cladding
Not possible with TVRK
- **Accessories**
Secondary silencer, for rooms with more stringent requirements on comfort
Lip seal
Reheat unit

Easy types

**Air terminal units for standardised applications
Easy in the whole configuration**

- **Selection based on nominal size of duct**
Facilitates ordering and allocation at the construction site
- **Volume flow adjustment**
Read adjustment value from the volume flow scale of the controller and set at the potentiometers
- **Functional check**
An indicator shows the set state

*Bluewater Retail-Park,
Greenhithe, England*



TVZ-Easy/TVA-Easy – VAV unit



TVR-Easy – circular controller



TVJ-Easy/TVT-Easy – rectangular controller



- **Control units for variable volume flow systems**
- **Air-tightness at full shut-off**
Leakage air flow pursuant to DIN EN 1751
Exception: TVJ-Easy
- **TROX Compact controller**
Tried-and-tested technology comprising of a transducer, controller and actuator
- **Factory functional testing of each unit**
Units are essentially ready for commissioning after installation
No on-site calibration required
- **Adjustment of the volume flows possible**
Adjustment of the required volume flows (\dot{V}_{\min} and \dot{V}_{\max}) directly at the controller, without an adjuster unit
- **Measurement and display of the current volume flow**
The current actual value of the air flow provided as a voltage signal
- **Unit variants with acoustic cladding**
If the case-radiated noise is not adequately reduced by the respective false ceiling, the solution is a unit with additional acoustic cladding
- **Accessories**
Secondary silencer, for rooms with more stringent requirements for comfort
Reheat unit
Lip seal

Volume flow measurement equipment

Volume flow measurement equipment

Measurement equipment for supply or extract air in room air conditioning systems of all types



Klinikum, Düsseldorf,
Germany

VMR – circular measuring unit



VME – rectangular measuring unit



VMRK/VMLK – circular plastic measuring unit



- **Manual detection of the air flow**

Measurement of the differential pressure and calculation of the air flow for commissioning, acceptance or testing

- **Continuous air flow measurement**

Conversion of the differential pressure measurement of a transducer into a voltage signal and then display or integration into the building management system

- **Measured value detection for tracking controller**

Measures the total air flow of a duct section, which might be pressure-controlled, for example, and enables tracking control of, for example, the extract air, with the same percentage

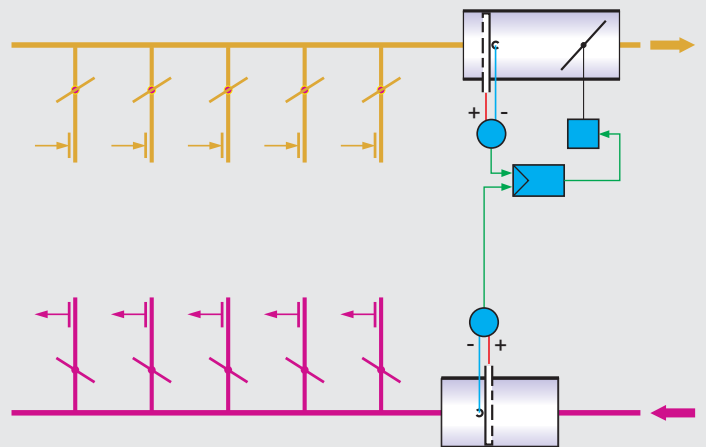

EXCONTROL

Building components for explosion zones

Control and shut off
in explosion-hazardous areas



RN-Ex/EN-Ex – mechanical system-powered



TVR-Ex – circular controller



AK-Ex – shut-off damper



- **ATEX 95 Directive**

The basis for configuring electrical equipment in explosion-hazardous areas is the ATEX 95 Directive

- **Area of validity**

TROX products are suitable for explosion-hazardous areas of Group II, Zones 1 and 2

- **ATEX-compliant construction**

Components coming into contact with the air flow, made of stainless steel and thus resistant to chemicals (DIN 8078)

- **ATEX certification**

TROX units designed and certified pursuant to ATEX criteria
Manufacturer certificates are available for electrical components



Special solutions



Scope of application: business and industry
VARYCONTROL TVRK, VMRK and
LABCONTROL TVLK

TVLK – fume cupboard controller



TVRC – comfort volume flow controller



Easy-Set – refurbishment set



Control equipment for laboratories

- **Controllers for fume cupboards**
Variable volume flow control taking into account safety requirements for window sill air inlet velocity
- **Control components can be used on bus or decentralised**
TROX controller with LONWorks technology or as standalone system and controllers from well-known controller manufacturers make project-specific solutions possible
- **Factory volume flow calibration and functional testing of each unit**
Units are essentially ready for commissioning after installation
No on-site calibration required

Comfort controllers for hotels and ships

- **Control systems for variable volume flow systems**
Air terminal unit including electric reheat and control panel
- **Safety systems**
Flow monitoring, temperature limitation and safe temperature control provide the best possible safety
- **Required tests**
EMC tests, conformity tests, high-voltage tests, Det Norske Veritas and Germanische Lloyd certificate

Set for refurbishing volume flow terminal units

- **Newly developed differential pressure sensor**
Measurement of the volume flow based on the dynamic differential pressure principle
- **TROX compact controller**
Differential pressure transducer, controller and actuator as a single unit
- **Easy principle**
Functional check via green indicator light

Balancing and shut-off

Cinemaxx, Wuppertal,
Germany



TDK – balancing damper



AK – circular shut-off damper



JZ – rectangular shut-off damper



Balancing damper for supply or exhaust air

- **Adjustment based on duct network calculation**
Every balancing damper has a diagram
Determine the setting angle from the pressure differential to be controlled and the flow velocity and adjust the unit
- **Adjustment with air flow measurement**
Measure the air flow based on the applicable standards for acceptance of room air conditioning systems (EN 12599) and make the relevant adjustment
- **Adjustment of duct pressures**
Measure the static pressure of a duct section and adjust the balancing damper

Shut-off damper for supply or extract air

- **Air-tightness at full shut-off**
Leakage air flow pursuant to DIN EN 1751
- **Manual actuation**
- **Electronic or pneumatic actuator**
Actuators for supply voltage 24 V or 230 V from well-known controller manufacturers enable project-specific solutions
- **Plastic construction**
Circular shut-off dampers also available in plastic; type AKK

Accessories



Real-Markt, Kamp-Lintfort, Germany

Hot-water reheat coil



Electric reheat unit



Silencer



Reheat of supply air

- **Hot-water reheat unit**
Two row heating coil sized for VAV units
- **Electric reheat units**
Electric reheat units for circular air ducts, including over-temperature protection
- **Great comfort**
The room air conditioning system maintains a comfortable room temperature, also in heating mode
With local reheat units space heat up is very rapid

Additional reduction of air flow regenerated noise

- **System attenuation**
Silencer sized for the particular unit type for easier installation
- **Low room sound pressure level**
Further reduction of the air flow regenerated noise of the air terminal unit with a secondary silencer
Silencer optimised so that its own regenerated noise is also low
Radiated noise from downstream duct work is also reduced

Installation accessories

- **Lip seal**
Push fit sealing system for circular air ducts pursuant to DIN EN 1506 or DIN EN 13180

Room temperature controller

System solution for decentralised room temperature control

The individual room control, together with the air terminal unit and its control components, form a functional package for optimum control of the individual room temperature with the lowest energy use.

Three unit options are available with various output sequences suitable for a range of applications including air-water systems.



Room temperature controller with user interface

CR24-B1

Individual room controller with an output for purely VAV systems.

CR24-B2

Individual room controller with two outputs for VAV systems and hot-water heating (reheat unit or radiators).

CR24-B3

Individual room controller with three outputs for VAV systems and additional heating and cooling functions.

Functions

(selection)

● Comfort mode

The comfort setpoint values (heating/cooling) are maintained. All control functions are enabled.

● Power cut-off

The controller cuts off the control functions and only allows protection modes i.e. for frost. This function is usually active when a window is open.

● Standby

The room is maintained in a state from which the comfort setpoint values can be quickly reached again. Thus, the cooling setpoint value is raised and the heating setpoint value lowered.

● Change over

A function required when the air conditioning system is operated with warm or cold air depending on the time of year; the direction of control is reversed.

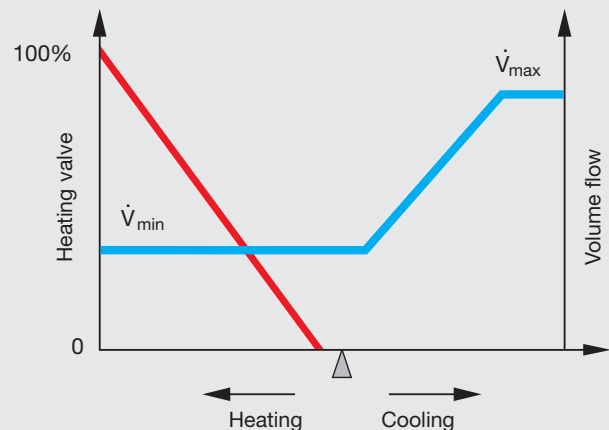

Control diagram with heating and cooling modes

Control concepts

Unit concept for control

The overall control of a room or zone consists of several individual functions. We will consider only the functions relevant for air conditioning here.

As described above, control occurs with one control circuit each for the room temperature and the volume flow. Each control circuit has a measuring element, a setpoint value unit, a controller and an actuator.

Room temperature control circuit:

- temperature sensor
- setpoint value adjuster
- room temperature controller

Volume flow control circuit:

- differential pressure transducer
- volume flow controller
- actuator

These functions can be achieved with separate units. Since the installation and wiring expenditure for this solution is considerable, controller manufacturers have developed units that combine two or more functions.



Scope of application: teaching and research VARYCONTROL TVZ and TVA with control components for integration in building management system and RN/EN University of Maastricht, Netherlands

An appropriate solution for a variety of applications is the combination of air conditioning functions into a so-called compact controller and the integration of the temperature sensor and the setpoint value adjuster in the room temperature controller casing. In this case, there is a clear assignment of warranty to the ventilation and control suppliers. Integration into the building management system is possible, but often not provided.

A variety of concepts are available on the market to fulfil project-specific requirements. The following overview shows several possibilities.

Function with separate unit	
Function	Purpose
Temperature sensor	Measurement at another location, e.g. in the extract duct
Setpoint value adjuster	Controller and/or sensor not in the occupied zone
Room temperature controller	Controller as function module in a DDC
Differential pressure transducer	Usually when static pressure function is required, but not available as a compact controller
Actuator	Greater actuating torque required, or spring return specified
Volume flow controller	Certain functions, e.g. override controls required, or transducer or actuator are separate

Control components

Compact controller as a solution for many applications

Combining several functions in a single casing facilitates installation and wiring.

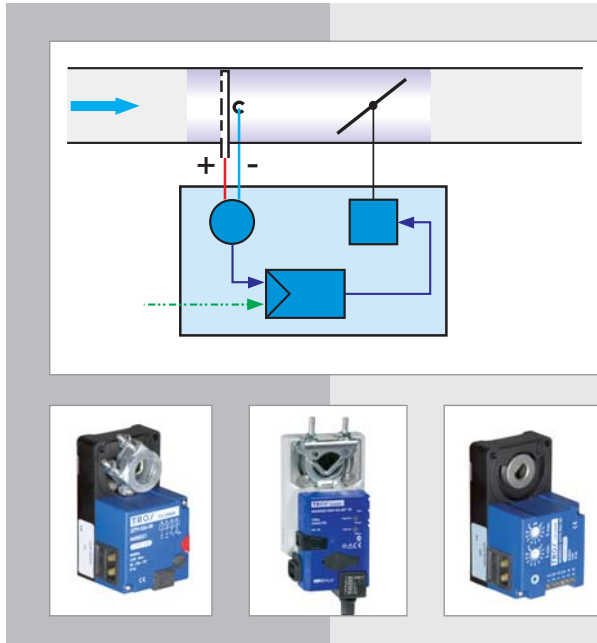

Compact unit

- differential pressure measurement
- volume flow controller
- actuator

Volume flow adjustment

The volume flows \dot{V}_{\max} and \dot{V}_{\min} are stored as parameters. An adjuster unit is required for altering the values. It also enables remote adjustment, thus it avoids the necessity for access through the false ceiling. If adjustment directly at the controller is desired, we recommend the TROX Compact (Easy).

227V / NMV-D2-MP / TROX Compact (Easy) – compact controller

Universal controller for special applications

Some applications require the selection of a universal controller, e.g. for override of groups of controllers. If spring return actuators are to be used for fire-safety functions, a universal controller is also necessary.

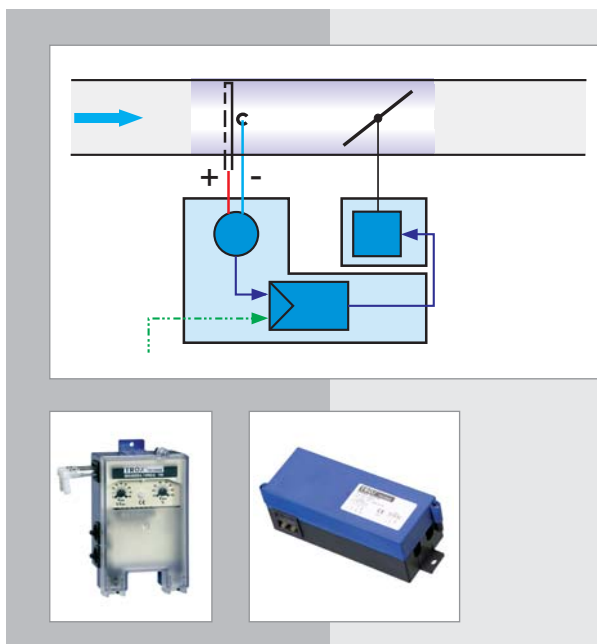

- **Controller/Transducer and actuator separate**
Specified actuator to provide greater torque or provide a safety function (spring return)
- **Volume flow adjustment**
The volume flows \dot{V}_{\max} and \dot{V}_{\min} are set at potentiometers. This requires access to the unit, but dispenses with the need for the adjuster unit. (VRD2 only)

VRD2 / GUAC-D3 – universal controller

Static pressure measurement mode for extract air containing dust

The differential pressure sensing based on static pressure measurement is possible with a separate diaphragm pressure transducer.

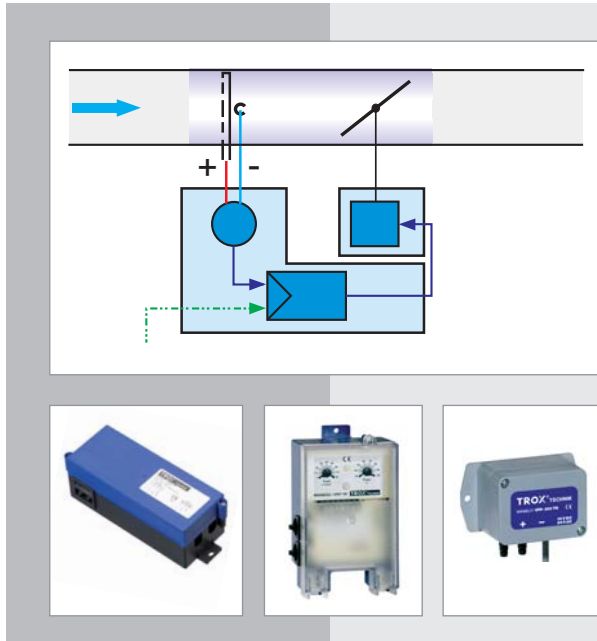

- **Diaphragm pressure transducer**
For contaminated extract air or for rapid measured value detection
- **Separate actuator**
Combination with standard operating mechanism, high torque or safety function is available

GUAC-S3 / VRP / VFP300 – controller with static pressure transducer

Control system for laboratories, hospitals and clean rooms

Self-adapting controller with high-speed actuators for areas where rapid responses are required. These might include fume cupboards or pressure regulated relatively air-tight rooms.

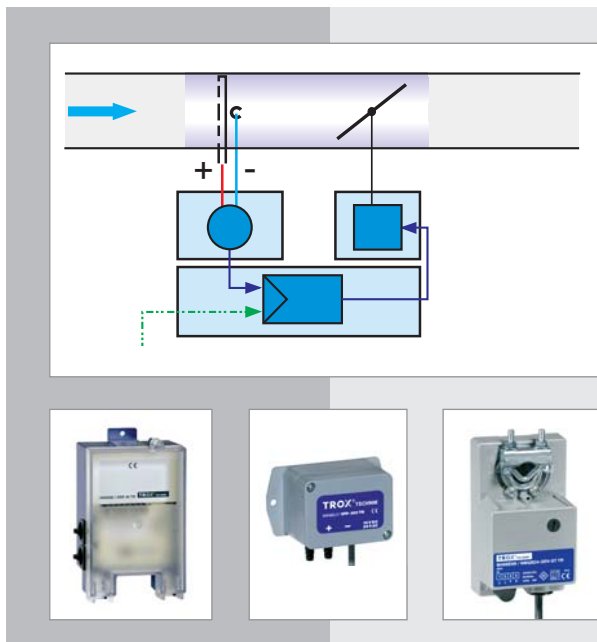

- **Diaphragm pressure transducer**
For contaminated extract air or for rapid measured value detection
- **High-speed actuator**
For a 90° angle of rotation, this actuator requires only 5 seconds
Results in rapid control response
Unit size has upper limit

VRP-M / VFP300 / NMQB24-SRV-ST – controller with static pressure transducer and high-speed actuator

Differential pressure controller for room pressure or duct pressure control

Air terminal units can also be used to control room pressure differentials and duct pressures.

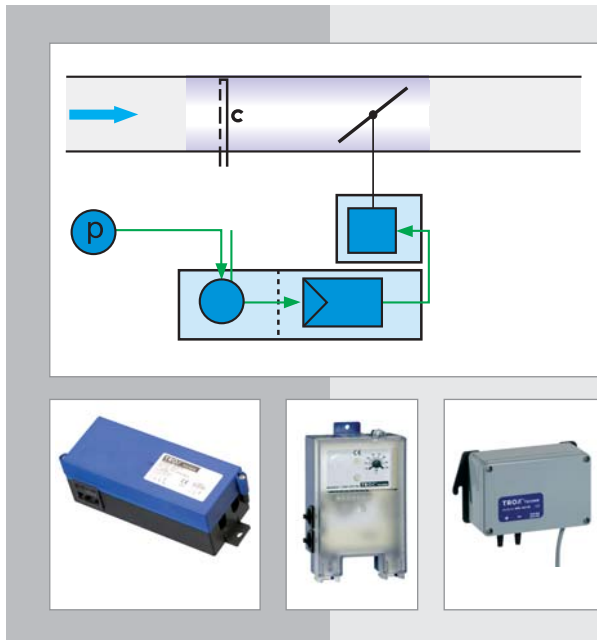

- **Diaphragm pressure transducer**
Measurement range of 100 Pa for room pressure control and 600 Pa for duct pressure control
- **Setpoint value adjustment**
Adjustment of the setpoint value of pressure at a potentiometer. This requires access to the unit, but dispenses with the need for the adjuster unit. (VRP-STP only)

GUAC-P1(P6) / VRP-STP / VFP100(600) – duct pressure and room pressure controller

Damper actuators

- **Volume flow control**
Optimised as actuator for volume flow control
- **Voltage supply**
Voltage supplied by controller, i.e. no separate wiring required
- **Run time**
Approx. 120 to 300 seconds for 90°. Guaranteed stable control of the volume flow
Control of the fan speed also remains stable with this approach



Damper actuator

- **Standard**
Torque sufficient for all TROX units with circular duct connection and smaller rectangular controllers

Spring return actuator

- **Safety function**
If the voltage supply fails, the actuator moves to the end stop. This must be specified on the order then the actuator is installed accordingly

Damper actuator with high torque

- **Power pack**
High torque, especially for large-area rectangular dampers

System integration

Integration into building management system

Energy management for all room air conditioning systems of a building does not make sense without the integration of air distribution into the building management system (BMS).

Switching to the actual values is sufficient for central display and logging of the local conditions. Additional control tasks and access to the parameters can only be achieved with the corresponding bus technology.

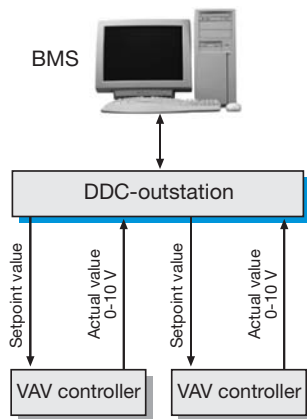

Switching on voltage signals

Measured value recording (monitoring)

The volume flow controller provides the actual value of the air flow in the form of a voltage signal. This data item is integrated into the building management system linked with the analogue input of a DDC outstation.

DDC control

The room temperature control loop is in the DDC outstation in this case. The setpoint value reaches the volume flow controller via the analogue output.

Standardised bus communication

LONWorks

LONWorks is a company-independent open technology for building automation. The control components, even those from different manufacturers, communicate with one another by exchanging standardised variables. Centralised communication and control is optional. This allows for partial operation even if several units fail.

System integration

Functioning of the control circuits, which traditionally have conventional wiring, occurs with a logical variable link (binding) with LON technology. Consideration of system integration must be addressed in the design stages and should only be entrusted to engineers with experience in this activity.

LON units

Every field unit featuring a LON network chip is integrated directly. Other units require a LON coupler, which converts the voltage signals into network variables. An additional system allows the connection of up to eight volume flow controllers to a LON coupler.

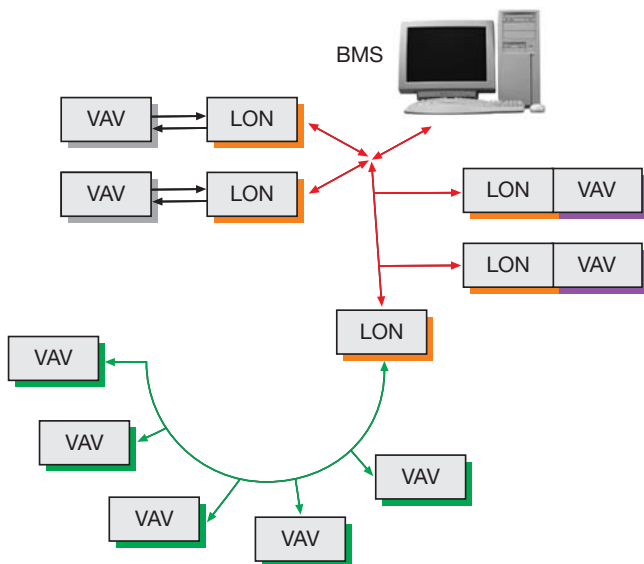

Design criteria

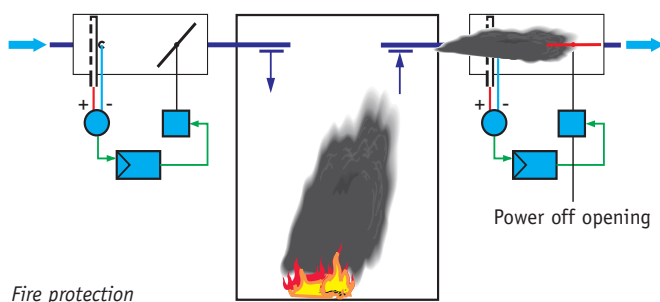
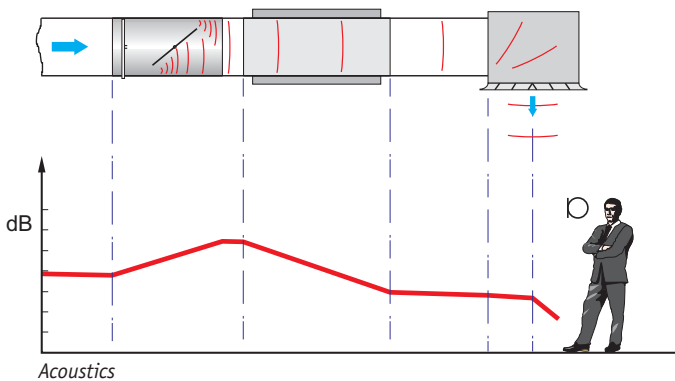
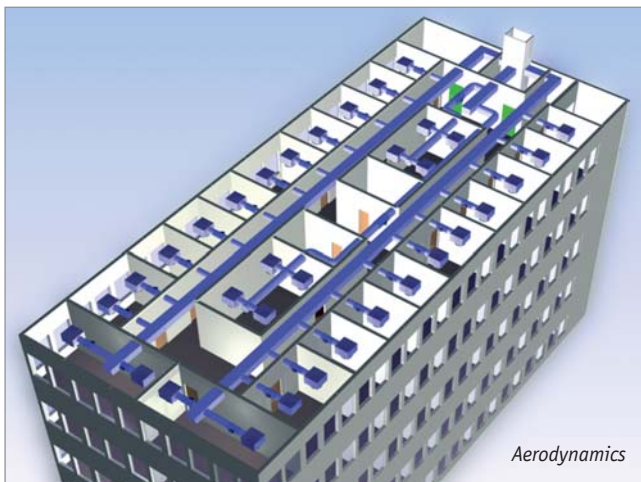
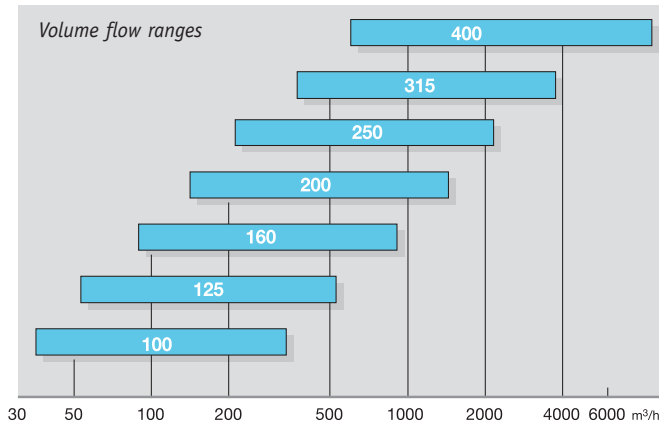

Checklist for selecting air terminal units

- **Volume flow ranges**

Primarily, the units are sized based on the maximum air flow (\dot{V}_{max}). We recommend not going as high as the nominal air flow (\dot{V}_{nom}), but rather leaving the scope for subsequent increase.

- **Aerodynamic design**

Design of the ducting layout and duct pressure control are carried out with consideration of the minimum pressure differential. You must ensure that sufficient air duct pressure is available under every operating condition and for every controller.

- **Acoustic design**

Allowances have to be made for all noise sources to establish an estimate of sound pressure level in the room. If the preliminary calculations in terms of a single figure criteria (db(A), NC) shows values that approach the specified room requirements we recommend that a detailed octave band analysis is undertaken.

- **Control components**

The selection of control components is carried out based on the overall control concept. The deciding factor is the issue of whether the individual controllers are to be integrated into networks in the building management system or whether a decentralised standalone system is configured. For compact controllers, there are options for either system.

- **Fire protection**

Air terminal units can be included in fire protection design, for example, safety related actuators which allow rapid smoke removal in case of fire.

- **Installation design**

In the design phase, you should ensure that the control components mounted on the units remain accessible for commissioning and maintenance.

- **Materials, hygiene**

The materials of the units must be tested for special applications. For example, the cleanliness classes required for clean rooms.

- **Installation accessories**

Installation accessories such as lip seals provide a quick and simple installation of the units.

Documentation



Technical leaflet

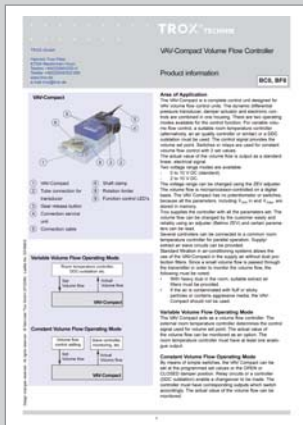

Product information

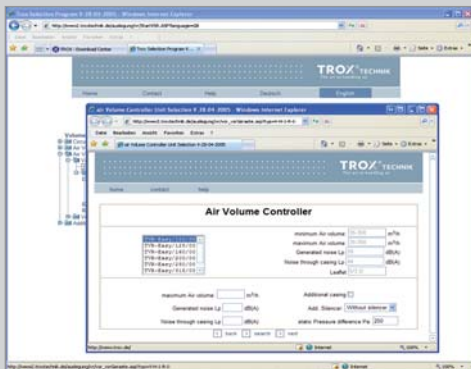

Design program



Internet

Technical leaflet

• Technical data

Unit description, materials, aerodynamic and acoustic data and dimensions are contained in the technical leaflets.

• Specification texts

All the important features of the unit and the materials used are described in the specification texts. These texts ensure that only high-quality units are accepted.

Product information on the control components

• Areas of application and functional description

The project-specific selection of control components can be carried out reliably based on product characteristics

• Operation

For commissioning, it is especially important to know what parameters are available, how they can be set and how this is performed.

• Wiring and commissioning

Wiring examples can be used directly with many applications. Information on commissioning helps the technician on site.

Selection of the units with the design program

• Menu-driven operation

Easy operation of the program interface, just as many other Windows and Internet applications.

• Unit selection

A systematic review of function characteristics and material requirements occurs using a search tree, with the result being an appropriate project-specific unit selection.

• Project management

The design results: Specification texts, prices, acoustic and aerodynamic data are saved and assigned to specific projects.

TROX on the Internet

• www.troxtechnik.com

All documentation is published on the Internet

Unit selection

Type	TVM	TVZ	TVZ-Easy	TVA	TVA-Easy	TVR	TVR-Easy
System type							
Supply air							
Extract air							
Dual-duct (supply air)							
Air duct connection, high-pressure side							
Circular							
Rectangular							
Volume flow range							
to m ³ /h	6048	6048	6048	6048	6048	6048	6048
l/s	1680	1680	1680	1680	1680	1680	1680
Air quality							
Filtered							
Office extract air							
Dirty				T, A	T, A	T, A, D	T, A, D
Contaminated							
Control function							
Variable							
Constant							
Min/Max							
Pressure control	T, A						
Master/Slave	M						
Maximum limitation							
Full shut-off							
Leakage							
Air-tightness							
Acoustic requirement							
High <40dB(A)	D	D	D	D	D		
Mid <50dB(A)						A	A
Low							
Other functions							
Measurement							
Volume flow							

D: possible with particular equipment; T: with approval from TROX; A: possible with certain accessories



3690	36360	36360	36360	36360	5040	504	12096	900
1025	10100	10100	10100	10100	1400	140	3360	250

T	T, A, D	T, A, D	T, A, D	T, A, D	T, D	T, D	T, D	T
					T, D		T, D	T

					A		A	

	D, A	D, A	D, A	D, A	D, A		D, A	
T	A	A	A	A	A		A	

Project execution

TVZD/160/D1/XB0/E0-320-780m³/h

Order code



Online customer centre – TROX NET



Commissioning



Maintenance

Rapid order processing with unique order code

- **Order**
We recommend using TROX order codes when ordering. They uniquely identify our products and avoid the need for return inquiries.
- **Order confirmation**
The units are always defined by their order code in the order confirmation.
- **Order status on the Internet**
Every customer has the option, after activation, of tracking the status of his/her orders on our websites.

Factory calibration facilitates commissioning

- **Wiring**
All control components installed on the unit are wired at the factory. At the construction site, only the external connections need to be attached and the wiring checked.
- **Functional testing**
Since all volume flow-relevant parameters have been adjusted, commissioning is limited to functional testing. The \dot{V}_{\min} and \dot{V}_{\max} may need to be set using the scale. Measurements are not required.

Air terminal units are mechanically maintenance-free

- **Functional testing**
The units are mechanically maintenance-free, i.e. no lubrication work is necessary. Annual functional testing is recommended and for certain industrial applications it is required.
- **Diaphragm pressure transducer**
The output signal of diaphragm pressure transducers is not stable in the long-term. Checking and adjusting of the zero point is required at least once annually. This service is not required for newer transducers with automatic zeroing.

Commissioning



Visual checking



Commissioning with adjuster

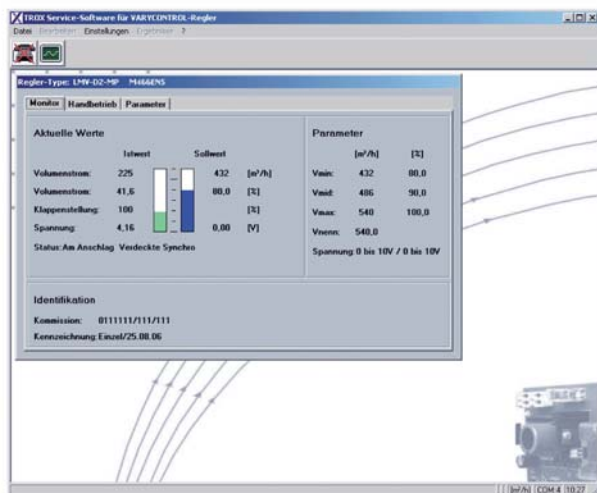

Commissioning with TROX Service Tool

Air flow testing

The requirements for commissioning and acceptance of air conditioning systems are stipulated in DIN EN 12599. The functionality of the system is then to be verified. Measurement of the air flows is extremely helpful here, as both the function and the output are confirmed to be correctly set.

Adjustment and monitoring control directly at the controller

Universal controllers have adjustment potentiometers for V_{\min} and V_{\max} . Measurement of the air flow occurs via a voltage signal.

With the TROX Easy controller, an indicator shows whether the air flow is as it should be.

Commissioning with adjuster units

Controllers without adjustment potentiometers cannot be reset without additional aids. One possibility is the use of an adjuster unit. Potentiometers or buttons and a display are used to reset the values.

Remote adjustment, for example from the switch gear cabinet, is an advantage when the required signal is wired to this location.

Commissioning with laptop and the TROX Service Tool

A Service Tool provides the most options. The laptop is connected to the volume flow controller via an interface. All values are displayed clearly in physical units. Changes are made simply and securely.

The recording of trends is possible and is very helpful when commissioning.



References



*Burj Al Arab,
Dubai, United Arab Emirates*

References

Airport

Hamburg

Airport

Munich

Antenne Bayern

Munich

Arena auf Schalke

Gelsenkirchen

Axel Springer

Berlin

BASF

Ludwigshafen

Bausparrkasse

Schwäbisch Hall

BHW

Hamel

BMW

Munich

Boehringer

Ingelheim

Campeon Neubiberg

Munich

Commerzbank

Nuremberg

Dresdner Bank

Düsseldorf

Eurogress

Aachen

Forschungszentrum

Jülich

Givaudan Aromen

Dortmund

Herzzentrum at the University of Cologne

Cologne

Hochhausensemble Münchener Tor

Munich

Hochzeitshaus

Hamel

Hotel Quellenhof

Aachen

Ice Rink

Mannheim

IMOTEX

Neuss



*Central Station,
Berlin, Germany*

Kaufhaus Breuninger

Nuremberg

Kö-Haus

Düsseldorf

Lehrter Bahnhof Bügelbauten

Berlin

MST.factory

Dortmund

NRW-Bank

Düsseldorf

Oldenburgische Landesbank

Oldenburg

Parkhotel

Euskirchen

Peek & Cloppenburg

Düsseldorf

Roche Deutschland

Penzberg

RWTH

Aachen

Siemens

Munich

Sparkasse

Wuppertal

Stadtcenter

Düren

Technical School

Krefeld

Tierlabor

Erlangen

University of Duisburg

Duisburg

BBC

London, UK

Biblioteca Municipal

Pamplona, Spain

Burj al Arab

Dubai, United Arab Emirates

Guggenheim Museum

Bilbao, Spain

Hotel Hilton

Sao Paulo, Brazil

La Cité de l'eau

Paris, France

Millenium-Tower

Vienna, Austria

Nestlé

Copenhagen, Denmark

Palazzo di Giustizia

Turin, Italy

Parlamento de Navarra

Pamplona, Spain

Tirolean National Clinic

Innsbruck, Austria

Torre Nord - San Benigno

Genoa, Italy

Vienna Twin-Towers

Vienna, Austria

Vifor

Fribourg, Switzerland

Head Office Germany

TROX GmbH

Heinrich-Trox-Platz

D-47504 Neukirchen-Vluyn

Phone +49(0)28 45 / 2 02-0

Fax +49(0)28 45 / 2 02-2 65

E-Mail trox@trox.de

www.troxtechnik.com

Subsidiaries

Australia

TROX Australia Pty Ltd

Austria

TROX Austria GmbH

Belgium

S.A. TROX Belgium N.V.

Brazil

TROX do Brasil Ltda.

Bulgaria

TROX Austria GmbH

China

TROX Air Conditioning Components
(Suzhou) Co., Ltd.

Croatia

TROX Austria GmbH

Czech Republic

TROX Austria GmbH

Denmark

TROX Danmark A/S

France

TROX France Sarl

Germany

FSL GmbH & Co. KG
HESCO Deutschland GmbH

Great Britain

TROX UK Ltd.
TROX AITCS Ltd.

Hong Kong

TROX Hong Kong Ltd.

Hungary

TROX Austria GmbH

Italy

TROX Italia S.p.A.

Malaysia

TROX Malaysia Sdn. Bhd.

Norway

TROX Auranor Norge AS

Poland

TROX Austria GmbH

Russia

TROX Klimatechnika

Serbia & Montenegro

TROX Austria GmbH

South Africa

TROX South Africa (Pty) Ltd

Spain

TROX España, S.A.

Sweden

TROX Auranor Svenska AB

Switzerland

TROX HESCO Schweiz AG

United Arab Emirates

TROX Middle East (LLC)

USA

TROX USA, Inc.

Foreign Representatives

Abu Dhabi

Argentina

Bosnia-Herzegovina

Chile

Cyprus

Egypt

Finland

Greece

Iceland

India

Indonesia

Iran

Ireland

Israel

Jordan

Korea

Latvia

Lebanon

Lithuania

Netherlands

New Zealand

Oman

Pakistan

Philippines

Portugal

Romania

Saudi Arabia

Slovak Republic

Slovenia

Sweden

Taiwan

Thailand

Turkey

Ukraine

Uruguay

Venezuela

Vietnam

Zimbabwe